

## 楔形2爪ホローチャック

### WEDGE-HOOK type 2-JAW THROUGH-HOLE POWER CHUCK

#### 特長 Technical features

1. 異形ワークの把握に適した2爪ホローチャック。
  2. 大把握力で高速回転に対応し、大きな貫通穴をもっています。
  3. ワークの一部を貫通穴に挿入しての把握や、バーワークを主軸後側から供給しての把握ができます。
1. 2-jaw hollow chuck suitable for clamping irregular shaped workpieces.
  2. Supports large clamping forces and high speeds and has a large through-hole.
  3. Can clamp part of a workpiece inserted into the through-hole, and can feed and clamp a bar workpiece from the rear of the spindle.

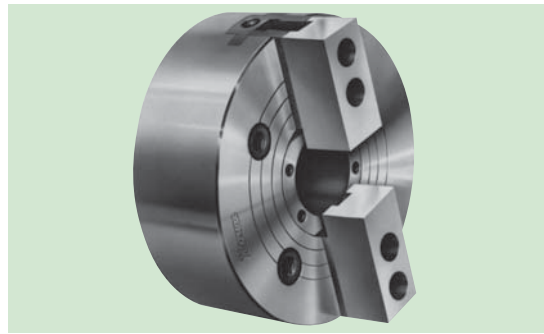

仕様 Specifications		形式番号 Series number	H034M				
			6	8	10	(12)	(15)
セレーションピッチ Serration pitch	mm		1.5	1.5	1.5	1.5	---
			---	---	---	---	3
爪のストローク (直径にて) Jaw movement (Dia)	mm		6.3	7.6	9.3	10.6	11.9
プランジャストローク (シリンダストローク) (Cylinder stroke)	mm		15	18	22	25	28
最大・最小把握径(外径) Recommended outside chucking diameter for standard soft blank jaws	最大 Max.	mm	165	210	254	304	381
	最小 Min.	mm	18	12	16	38	60
最高使用回転数 Max. Speed	r/min		5800	4800	4200	3200	2500
許容シリンダ力 Max. input force	kN		12.7	19.6	26.5	32.4	46.1
把握力 Clamping force at Max. input force (Total jaw force)	kN		38.2	55.9	75.5	93.2	127
慣性モーメント 注1 Moment of inertia J Note 1	kg·m <sup>2</sup>		0.050	0.16	0.34	0.83	2.30
質量 Weight with standard soft blank jaws	kg		13.7	25	39	68.6	112.1
対応シリンダ Matching cylinder							
C1TA	形式番号 Series number		115	140	165	190	(215)
	最高使用圧力 Max. pressure to operate chuck	MPa	1.8	1.7	1.9	1.7	2.2
HH4C	形式番号 Series number		80	100	125	140	160
	最高使用圧力 Max. pressure to operate chuck	MPa	3.0	2.8	2.4	2.3	2.5
H05CH	形式番号 Series number		200	250	300	300	300
	最高使用圧力 Max. pressure to operate chuck	MPa	0.4	0.4	0.4	0.5	0.7

記号 Symbol	形式番号 Series number	H034M				
		6	8	10	(12)	(15)
A		168	210	254	304	381
B2	Min.	61	68	92	110	140
C	H7	140	190	230	280	350
D		5	5	5	5	7
E		82	92	105	115	137
F		104.8	133.4	171.4	200	250
G		M10	M12	M16	M20	M20
H		14	16	22	26	26
J	Max.	M55×2	M60×2	M85×2	M100×2	M130×2
J1		35	40	45	50	60
K		30	32	37	42	48
L1	Max.	15	18	22	25	28
	Min.	0	0	0	0	0
L2		20	23	27	30	35
M		45	52	75	91	118
N	Max.	36.25	38.8	53.3	63.8	81.5
	Min.	33.1	35	48.65	58.5	75.55
O	Max.	18	31.5	33	40.5	51
	Min.	6	9	12	10.5	12
Q		17	21	21	28	30
W1		59	66	90	108	139
X		39	44	49	64	69

注：( )の形式は受注生産です。  
Note: Parenthesized models are made to order.

- 注：1. この値の4倍がGD<sup>2</sup>に相当します。  
2. 回転シリンダの最高回転数が低い場合には、その回転数に合わせてください。  
3. 把握爪の寸法は標準生爪寸法表を参照願います。
- Note: 1. The four times of this value is equivalent to GD<sup>2</sup>.  
2. When the Max. speed of a rotating cylinder is lower than that of a chuck, observe that of a rotating cylinder.  
3. The dimensions of top jaws are on the pages of "Standard soft blank jaw".

