

軽量形ステーションナリチャック

LIGHT WEIGHT STATIONARY CHUCK

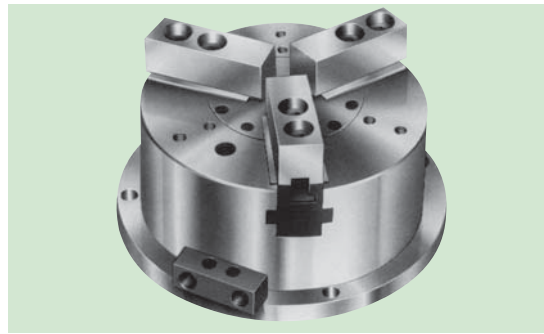

仕様 Specifications	形式番号 Series number	H012D				
		4	6	8	(10)	
セレーションピッチ Serration pitch	mm	1.5	1.5	1.5	1.5	
爪のストローク (直径にて) Jaw movement (Dia)	mm	5.5	5.5	7	7	
最大・最小把握径 (外径) Recommended outside chucking diameter for standard soft blank jaws	最大 Max.	mm	110	165	210	254
	最小 Min.	mm	8	36	38	38
最高使用圧力 Max. pressure	MPa	0.7	0.7	0.7	0.7	
把握力 Clamping force at Max. input force (Total jaw force)	kN	7.8	20.6	33.3	51.0	
ピストン面積 Effective piston area	押側 Extend	cm ²	60.1	146.9	245.2	375.8
	引側 Retract	cm ²	57.7	140.5	236.7	360.6
ピストンストローク Piston stroke	mm	13	13	16.5	16.5	
質量 Weight with standard soft blank jaws	kg	6	15	26	40	

記号 Symbol	形式番号 Series number	H012D			
		4	6	8	(10)
A1		110	165	210	254
A2		147	203	248	300
A3		75	102.5	125	147
C	H8	35	50	60	80
E		75	85	100	105
F		130	185	230	280
G		9	11	11	13
H		10	12	12	14
J1		25	35	40	45
M		4	20	30	44
N	Max.	27	39	49	59
	Min.	24.25	36.25	45.5	55.5
O	Max.	9	16.5	21	27
	Min.	6	10.5	10.5	12
P		21	23	23	25
X		29	39	44	49
Z1		---	55	67	80
Z2		---	20	25	30
Z3	深サ Depth	---	M6 -10	M8 -13	M8 -13

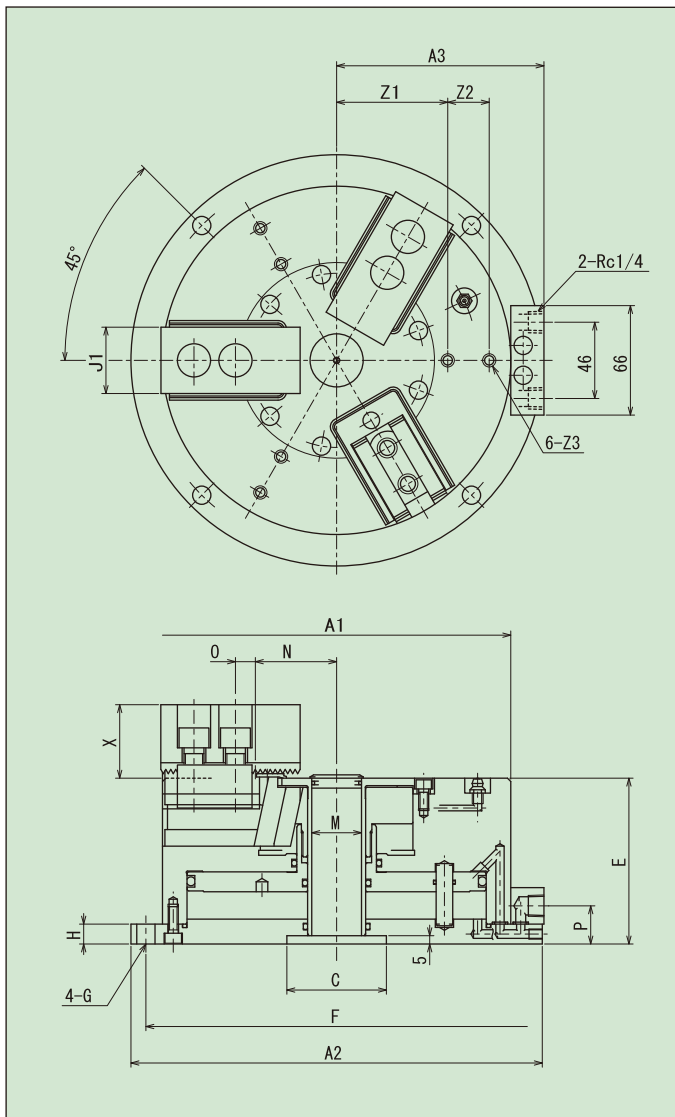

注：1.()の形式は受注生産です。

2. 把握爪の寸法は標準生爪寸法表を参照願います。

Note: 1. Parenthesized models are made to order.

2. The dimensions of top jaws are on the pages of "Standard soft blank jaw".

特長 Technical features

ボール盤、フライス盤などに使用する定置式のチャックです。とくに防塵を考慮し、取付け面からの高さをできるだけ低くするように設計しています。

Stationary chucks with three jaws for drilling milling and other machines.

Standard chucks with dust proof construction, designed for minimized height from mounting surface.