

## 3爪ドロダウンチャック 3-JAW DRAW DOWN POWER CHUCK

### 特長 Technical features

1. 従来形式のH011MBとの互換性を保っています。アダプタやトップツーリングもそのまま使用できます。
2. ワークを端面へ引きつけて把握しますので、ワークの浮上りがありません。
3. チャックボデーの材料には浸炭焼入れをおこない、また、シール構造や摺動面潤滑の改善などにより、耐摩耗性や防塵性など耐久性能が一層向上しています。
4. 外径把握専用のチャックです。このチャックは、内径把握はできません。

1. Compatible with the previous H011MB series. Also allows the use of an adaptor or top tooling.
2. Pulls the workpiece toward the end face to prevent it from lifting up.
3. Carburizing the chuck body and improving the sealing structure and lubrication of sliding surfaces has enhanced durability including wear resistance and dust resistance.
4. Dedicated chuck for external clamping. It cannot be used for internal clamping.

記号 Symbol	形式番号 Series number	H011MC					
		4	5	6	8	10	12
A		110	130	165	210	254	304
B1		98	118	---	---	---	---
B2	Min.	30	32	37	44	54	57
C	H7	60	80	140	190	230	230
D		5	5	5	5	5	5
E		60	70	85	95	110	125
F		80	100	104.8	133.4	171.4	171.4
G		3-M8	3-M8	6-M10	6-M12	6-M16	6-M16
H		14	14	16	18	22	22
J		M10 ×1.5	M12 ×1.75	M16 ×2	M20 ×2.5	M24 ×3	M27 ×3
J1		25	30	35	40	50	60
K		20	25	36	36	46	50
L	Max.	19	19	33	38	47	47
	Min.	12	12	23	28	32	32
N	Max.	37	44	58	71	85	102
	Min.	34.5	41.5	54.4	67.4	79.6	96.6
P	Max.	10.5	10.5	14	14	19	19
	Min.	3.5	3.5	4	4	4	4
R		---	---	15°	15°	15°	15°
W1		25	28	32	38	50	52
W2		28	30	35	42	52	55
X	Max.	30	35	45	55	65	70
	Min.	23	28	35	45	50	55
Z1		25	30	35	45	55	70
Z2		---	---	20	25	30	35
Z3	深さ Depth	M6 -11	M6 -12	M6 -12	M8 -16	M8 -16	M10 -20

仕様 Specifications	形式番号 Series number	H011MC						
		4	5	6	8	10	12	
爪のストローク (直径にて) Jaw movement (Dia)	mm	5	5	7.2	7.2	10.8	10.8	
プランジャストローク (シリンダストローク) (Cylinder stroke)	mm	7	7	10	10	15	15	
最大・最小把握径(外径) Recommended outside chucking diameter for standard soft blank jaws	最大 Max.	mm	110	130	165	210	254	304
	最小 Min.	mm	18	25	35	40	50	50
最高使用回転数 Max. Speed	r/min	3500	3500	3500	3000	2500	2000	
許容シリンダ力 Max. input force	kN	6.0	10	15	25	35	45	
把握力 Clamping force at Max. input force (Total jaw force)	kN	10.5	17	25	45	60	75	
慣性モーメント Moment of inertia J	kg·m <sup>2</sup>	0.007	0.016	0.051	0.15	0.37	0.79	
質量 Weight with standard soft blank jaws	kg	4.5	7.5	15	26	45	70	
対応シリンダ Matching cylinder								
HH4C	形式番号 Series number	63	80	100	125	140	160	
	最高使用圧力 Max. pressure to operate chuck	MPa	2.2	2.3	2.1	2.2	2.4	2.3
H05CH	形式番号 Series number	150	175	200	250	300	300	
	最高使用圧力 Max. pressure to operate chuck	MPa	0.4	0.4	0.5	0.5	0.5	0.6

- 注：1. この値の4倍がGD<sup>2</sup>に相当します。  
 2. 回転シリンダの最高回転数が低い場合には、その回転数に合わせてください。  
 3. 把握爪の寸法は標準生爪寸法表を参照願います。
- Note: 1. The four times of this value is equivalent to GD<sup>2</sup>.  
 2. When the Max. speed of a rotating cylinder is lower than that of a chuck, observe that of a rotating cylinder.  
 3. The dimensions of top jaws are on the pages of "Standard soft blank jaw".

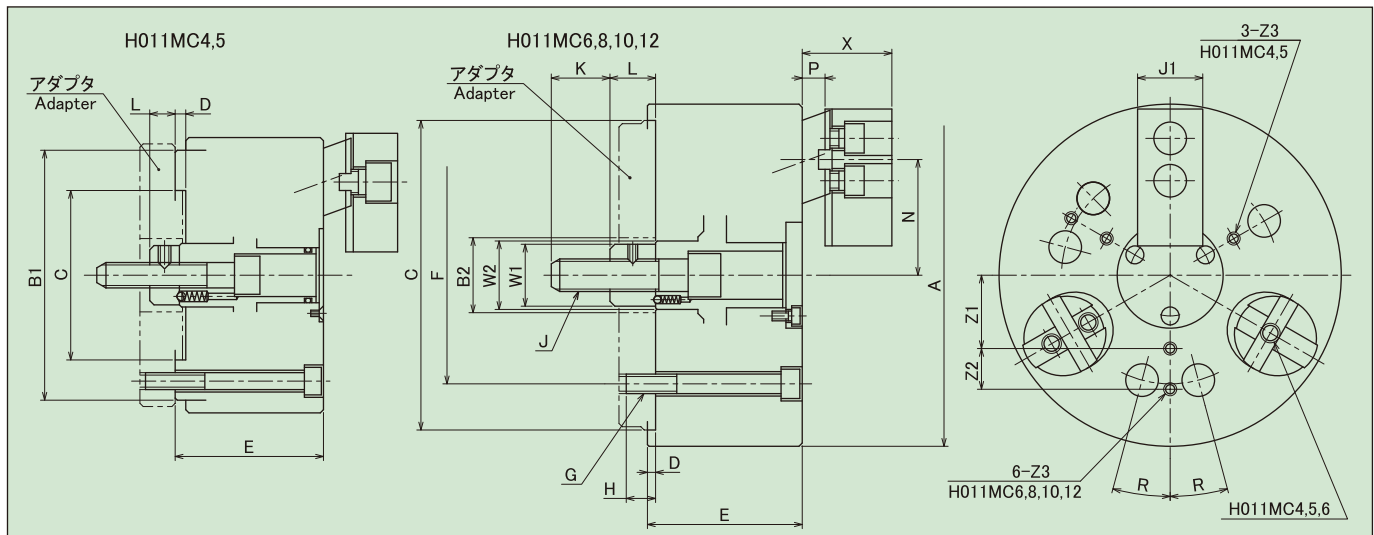
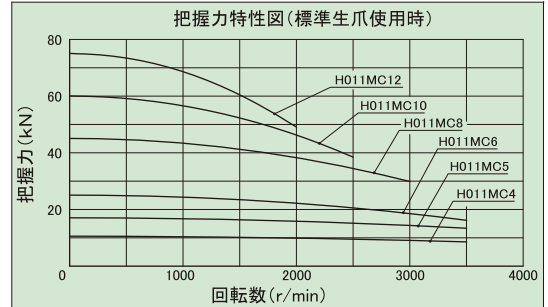

# H011MC□Z

## 3爪ドロウダウンチャック(流路付) 3-JAW DRAW DOWN POWER CHUCK with THROUGH-HOLE

### 特長 Technical features

H011MCの流路付仕様です。圧縮空気やクーラントを通すことができます。  
Through-hole is provided as standard for compressed air or coolant pass.

仕様 Specifications		形式番号 Series number	H011MC□Z				
			(5)	6	8	(10)	(12)
爪のストローク (直径にて) Jaw movement (Dia)	mm		5	7.2	7.2	10.8	10.8
プランジャストローク (シリンダストローク) (Cylinder stroke)	mm		7	10	10	15	15
最大・最小把握径(外径) Recommended outside chucking diameter for standard soft blank jaws	最大 Max.	mm	130	165	210	254	304
	最小 Min.	mm	25	35	40	50	50
最高使用回転数 Max. Speed	r/min		3500	3500	3000	2500	2000
許容シリンダ力 Max. input force	kN		10	15	25	35	45
把握力 Clamping force at Max. input force (Total jaw force)	kN		17	25	45	60	75
慣性モーメント 注1 Moment of inertia J Note1	kg·m <sup>2</sup>		0.016	0.051	0.15	0.37	0.79
質量 Weight with standard soft blank jaws	kg		7.5	15	26	45	70
対応シリンダ Matching cylinder							
C1SB	形式番号 Series number		95	95	115	125	135
	最高使用圧力 Max. pressure to operate chuck	MPa	1.7	2.6	2.7	3.4	3.5
H06C	形式番号 Series number		150	(200)	(250)	(250)	(250)
	最高使用圧力 Max. pressure to operate chuck	MPa	0.6	0.4	0.5	0.6	0.6

- 注：1. この値の4倍がGD<sup>2</sup>に相当します。  
2. 回転シリンダの最高回転数が低い場合には、その回転数に合わせてください。  
3. 把握爪の寸法は標準生爪寸法表を参照願います。  
Note：1. The four times of this value is equivalent to GD<sup>2</sup>.  
2. When the Max. speed of a rotating cylinder is lower than that a chuck, observe that of a rotating cylinder.  
3. The dimensions of top jaws are on the pages of "Standard soft blank jaw".

注：( )の形式は受注生産です。  
Note：Parenthesized models are made to order.

記号 Symbol	形式番号 Series number	H011MC□Z				
		(5)	6	8	(10)	(12)
A		130	165	210	254	304
B1		118	---	---	---	---
B2	Min.	32	37	44	54	57
C	H7	80	140	190	230	230
D		5	5	5	5	5
E		70	85	95	110	125
F		100	104.8	133.4	171.4	171.4
G		3-M8	6-M10	6-M12	6-M16	6-M16
H		14	16	18	22	22
J		M12×1.75	M16×2	M20×2.5	M24×3	M27×3
J1		30	35	40	50	60
K2		25	30	36	46	50
K3		16	16	18	20	20
K4		4	4	4	4	4
K5		2.5	2.5	3.2	3.2	3.2
K6		P6	P9	P12	P15	P18
L	Max.	19	33	38	47	47
	Min.	12	23	28	32	32
M1		44	---	---	---	---
M2	H9	11	15	20	25	25
M3	Max.	17	20	20	25	25
	Min.	10	10	10	10	10
M4	e9	9	12	16	19	22
M5		4	4	5	6	6
M6		2.5	---	---	---	---
N	Max.	44	58	71	85	102
	Min.	41.5	54.4	67.4	79.6	96.6
P	Max.	10.5	14	14	19	19
	Min.	3.5	4	4	4	4
R		---	15°	15°	15°	15°
W1		28	32	38	50	52
W2		30	35	42	52	55
X	Max.	35	45	55	65	70
	Min.	28	35	45	50	55
Z1		30	35	45	55	70
Z2		---	20	25	30	35
Z3	深サ Depth	M6-12	M6-12	M8-16	M8-16	M10-20

### 形番表示方法 Model Coding

H011MC□Z

